

namco[®]



OPERATOR'S MANUAL

Important

**Read PRECAUTIONS and INSTALLATION
Sections before operating game**

FCC Notice

Note: This equipment has been tested and found to comply with the limits for a Class A digital device, pursuant to Part 15 of the FCC Rules. These limits are designed to provide reasonable protection against harmful interference when the equipment is operating in a commercial environment. This equipment uses, and can radiate radio frequency energy and, if not installed and used in accordance with the instruction manual, may cause harmful interference to radio communications. Operation of this equipment in a residential area is likely to cause harmful interference in which case the user will be required to correct the interference at his own expense.

Copyright 2006 NAMCO AMERICA INC. - All rights reserved

No part of this publication may be reproduced by any mechanical photographic, or electronic process, or in the form of a phonographic recording, nor may it be stored in a retrieval system, transmitted, or otherwise copied for public or private use, without permission from NAMCO AMERICA INC.

TABLE OF CONTENTS

1.0	SPECIFICATIONS	1
2.0	INTRODUCTION	1
3.0	PRECAUTIONS	2
	3.1 Installation location	2
	3.2 Handling	2
4.0	MOVING AND TRANSPORTING	3
5.0	INSTALLATION	3
6.0	OPERATION	4
	6.1 PRE-SERVICE CHECK	4
	6.2 TEST MENUS	4
7.0	ADJUSTMENTS	5
	7.1 AUDIO ADJUSTMENTS	5
	7.2 CURRENCY AND PRICING ADJUSTMENTS	5
	7.3 GAME ADJUSTMENTS	7
8.0	AUDITS	7
	8.1 COIN AUDITS	7
	8.2 GAME AUDITS	8
	8.3 DETAILED GAME AUDITS	9
	8.4 CLEAR GAME AUDITS	10
9.0	DIAGNOSTICS	10
	9.1 AUDIO TESTS	10
	9.2 SWITCH TESTS	11
	9.3 LAMP TESTS	11
10.0	RESETS	12
	10.1 CLEAR AUDITS	12
	10.2 SET ALL ADJUSTMENTS TO DEFAULTS	12
	10.3 CLEAR COIN AUDITS	12
	10.4 CLEAR GAME AUDITS	12
	10.5 SET HIGH SCORES TO DEFAULTS	12
	10.6 SET HIGH SCORES TO BLANK	12

10.7	FACTORY DEFAULTS (CLEAR EVERYTHING)	13
10.8	SYSTEM INFORMATION	13
11.0	TROUBLESHOOTING	13
12.0	MAINTENANCE	15
13.0	GAME PLAY	15
13.1	THE BUTTONS	15
13.2	HOW TO BOWL, HOW TO BOWL BETTER	15
13.3	ABOUT THE GAMES	17
	1. REGULATION TEN PIN BOWLING	17
	2. TRICK SHOT	18
	3. TEN PIN POKER	18
	4. BLACKJACK BOWLING	19
14.0	OVERALL CONSTRUCTION	20
APPENDIX A:	PARTS LIST	22
APPENDIX B:	WIRING DIAGRAM	27

1.0 SPECIFICATIONS

Power Supply:	300 Watt, NAI # RB88-11529-00
Input Power:	120 VAC, 60 Hz, 3 Amps max.
Crated Dimensions:	69" H x 34.5" W x 35.5" D
Installed Dimensions:	60" H x 31" W x 32" D
Shipping Weight:	320 lbs
Controls:	1 Trackball, 4 pushbuttons
Convenience Kit:	Operator's Manual (1)

Note: *Specifications subject to change without prior notice. Modifications and/or alterations of the Bowl O Rama™ game with kits or parts not supplied by NAMCO may void the warranty.*

WARNING

REMOVAL OF SERIAL NUMBERS AND/OR BAR-CODES FROM PRODUCT OR COMPONENTS WILL VOID THE WARRANTY

2.0 INTRODUCTION

Namco's *Rockin' Bowl O Rama™* is a MULTI-player VIDEO game featuring trackball-controlled on-screen bowling, and 4 large push buttons that perform the following functions:

1. **START/SELECT (Checkmark Icon):** This button starts the game, resets the ball on the approach before taking a shot, selects shots in Trick Shot and selects cards in Ten Pin Poker.
2. **INSTANT REPLAY (Camera Icon):** This button plays a slow motion replay of the last shot. Press the button during the replay to change the camera angle.
3. **SCORESHEET (Score Box Icon):** Press and hold this button to bring up the score sheet during the game.
4. **JUKEBOX (Musical Notes Icon):** This button is used to change the song on the jukebox. Press it repeatedly to "break" the jukebox and shut it off. Press it again to start it back up.

3.0 SAFETY PRECAUTIONS

3.1 Installation location

This game is designed for indoor use only. It must *not* be installed outdoors. **The following conditions must be avoided:**

1. Direct exposure to sunlight, extreme high humidity, direct water contact, dust, high heat or extreme cold.
2. Vibration. The game must be installed on a level surface with levelers properly adjusted.

Do not install in an area such that the game would present an obstacle in case of an emergency (i.e., near fire equipment or emergency exists).

3.2 Handling

1. Before operating the game, make sure that the main AC power hookup includes a safety ground. This will ensure safe operation as well as compliance with the applicable FCC and UL regulations. Measure the AC power line voltage. Verify that the voltage source is between 110 and 125 VAC.
2. Before replacing any parts, turn the AC power OFF and unplug the game.
3. The game includes areas where 120 VAC is present. Take care at all times to avoid electrical shock whenever inspecting or adjusting the game.
4. Do not attempt to repair the Printed Circuit Board (PCB) on-site. It contains sensitive integrated circuit chips that could be easily damaged, even by the small internal voltage of a multi-meter. Always return the PCB to your distributor for any repairs. PCB assemblies must be returned as complete sets.

4.0 MOVING AND TRANSPORTING

The game is designed to be moved by a single person using an appliance dolly:

- 1) Position the appliance dolly behind the game.
- 2) Tilt the game slightly forward and slide the blade of the appliance dolly under the rear two legs of the game. Be sure that both legs are firmly in contact with the blade of the dolly and are not too close to the edge of the blade.
- 3) Run the strap of the appliance dolly around the front of the game and tighten snugly. Be sure the strap runs around the lower housing under the control panel. Do not run it around the edge of the control panel, as it may slip off. Do not over tighten the strap as it may damage the lower housing. Tighten it just enough to keep the game securely attached to the dolly.

The use of moving blankets is strongly suggested to prevent damage to the cabinet..

5.0 INSTALLATION

Setting the Leg Levelers

The game is equipped with six evenly spaced leg levelers under the base. After positioning the game as desired, run the leg levelers all the way in, or “up”. Then, turn the leg levelers out, or “down”, just enough to be sure that all six levelers are in contact with the floor and that the game does not tilt or wobble. If the game rocks or wobbles extend any legs that are not in contact with the floor by rotating them.

CAUTION!

THE LEG LEVELERS CAN BEND IF THEY ARE TOO FAR OUT!

Connecting the Power Cord

- 1) Ensure that the voltage selection switch next to the power supply input is set to the correct voltage (115 for US).
- 2) Insert the connector of the power cord into the power supply input socket located on the underside of the lower cabinet housing.
- 3) Insert the power cord plug into a service outlet.

Switching on the Power

- 1) Turn on the power switch located on the underside of the lower cabinet housing.
- 2) Wait for the game to power up. This may take a couple of minutes, during which time the screen will initially be dark.
- 3) After the machine has powered up for the first time perform the pre-service check (see Section 6.1, page 4, “Pre-Service Check”).

6.0 OPERATION

6.1 Pre-Service Check

Once the game has started up the first time perform a pre-service check to ensure everything is working correctly and that nothing was damaged or came loose in shipping. If any checks fail see page 16, "Troubleshooting".

- 1) The LCD display should be bright and clear and the game should be running in attract mode.
- 2) Unlock and open the coin door. Inside the door is a small bracket with four switches. Press the TEST switch to enter the test menus.
- 3) Roll the trackball or press the REPLAY and SCORESHEET buttons to highlight "diagnostics". Press START to go to the diagnostics menu.
- 4) Go to page 12, "diagnostics", and perform the audio, switch, and lamp tests to ensure that all inputs and outputs are operating correctly. The VOLUME UP, VOLUME DOWN, and SERVICE CREDIT switches are mounted along with the TEST switch on the bracket inside the coin door. The coin 3 input is connected to the dollar bill acceptor if the game is equipped with one. Be sure all four signals from the trackball are toggling correctly.
- 5) Exit the test mode. Either maneuver back through the menus or simply wait for test mode to time out and exit on its own.
- 6) Add credits, either by pressing the SERVICE CREDIT switch or by passing money through the coin slots.
- 7) Start up and play the game.

6.2 Test Menus

To enter test mode, press the TEST switch located on the inside of the coin door. The following main menu will appear:



The highlighted item will appear in red. Other items appear white. To change which item is highlighted press the REPLAY button to move up or the SCORE SHEET button to move down, or simply roll the trackball. Press the START button to select the highlighted item. After a period of inactivity test mode will automatically exit.

7.0 ADJUSTMENTS

Adjustments permit the operator to set various parameters and behaviors about the machine. In general, to change an adjustment, first highlight it (in red), then press START. The adjustment should turn green. Press REPLAY and SCORE SHEET (or roll the trackball) to change the adjustment to the desired value. Press START to save the new setting. The adjustment will return to red.

7.1 Audio adjustments

7.1.1 volume: 25 percent

This sets the volume from 5 percent (minimum) to 100 percent (full) in 5 percent increments. Pressing the volume up and volume down buttons inside the coin door will also change this adjustment.

7.1.2 jukebox volume (relative to main): 100 percent

Use this to set the jukebox (music) volume less than the sound effects volume. This is useful in locations where the game's music may compete with other sources of music in the location. It allows the operator to set the jukebox volume to be some fraction of the game's volume.

7.1.3 jukebox fadeout after game over: never

This adjusts how long the jukebox should continue to play the current track after the end of a game. Once this time is reached the track will fade out and cancel. If set to "never" the track playing at the end of the game will play until it ends. In any case, no additional tracks will start during attract mode after the end of a game.

7.1.4 back

Select this to return to the previous menu.

7.2 Currency and pricing adjustments

7.2.1 free play: off

Use this to turn free play on or off. When free play is on the remaining currency and pricing adjustments have no meaning.

7.2.2 currency: dollars (\$nn.nn)

Select the type of currency to use. Choices are dollars (\$nn.nn) or tokens.

7.2.3 value of coin 1: \$0.25

This sets the amount of money, which corresponds to a closure of coin switch 1 (the left coin switch). If currency is dollars and the left coin slot accepts quarters this should be \$0.25. If the currency is tokens this should be set to 1.

7.2.4 value of coin 2: \$0.25

Same as value of coin 1, except for the right coin switch (or center coin switch, if the door is equipped with three coin slots).

7.2.5 value of coin 3: \$1.00

Same as value of coin 1 or 2, except for the dollar bill acceptor (or right coin switch if the door is equipped with three coin slots).

7.2.6 value of mechanical count: \$0.25

This sets how much money corresponds to one count of the coin meter. For example, if currency is set to dollars and the coin meter is expected to show the money received in quarters this should be set to \$0.25. If currency is set to tokens this should be set to 1, so that 1 token yields 1 count.

7.2.7 price for a partial game: \$0.50

Use this to set the price per player of a partial game (five frames of regulation bowling).

7.2.8 price for a full game: \$1.00

Sets the price per player of a full game (ten frames of regulation bowling).

7.2.9 price for a three-game series: \$2.50

Sets the price per player of a three-game series of regulation bowling.

7.2.10 price for a trick shot game: \$1.00

Sets the price per player of a trick shot game.

7.2.11 price for a blackjack game: \$1.00

Sets the price per player of a blackjack game.

7.2.12 price for a ten pin poker game: \$1.00

Sets the price per player of a ten pin poker game.

7.2.13 back

Select this to return to the previous menu.

7.3 Game adjustments

7.3.1 trackball orientation

This is used to set the orientation of the trackball. The cabinet mounts the trackball in a rotated position. Be sure this is set to 45 degrees.

7.3.2 difficulty

Sets the difficulty of the game. Easier yields more pin action and reflections off the side walls, which generally leads to higher pin-fall.

7.3.3 shots which give cards in 10 pin poker: strikes and spares

In ten-pin poker players try to get the best poker hand. This adjustment determines whether a card is awarded for strikes and spares or just for strikes (more challenging)

7.3.4 length of blackjack game: 7 frame's

Due to the nature of the blackjack game it tends to have a higher average game time than the other games. This can be countered by reducing the length of the game. Available settings are 5, 7, or 10 frames.

7.3.5 back

Select this to return to the previous menu.

7.3.6 set all adjustments to defaults

Select this to set all adjustments to defaults. All audio, currency and pricing, and game adjustments will be reset to their factor default values. This cannot be undone.

7.3.7 cancel

Select this to leave all adjustments unchanged and return to the previous menu

8.0 AUDITS

8.1 Coin audits

8.1.1 coin 1: \$0.00

Amount of money recorded by coin 1.

8.1.2 coin 2: \$0.00

Amount of money recorded by coin 2.

8.1.3 coin 3: \$0.00

Amount of money recorded by coin 3.

8.1.4 total coins: \$0.00

Total money recorded.

8.1.5 service credits: 0

Number of service credits (service credits are added by pressing the service switch inside the coin door).

8.1.6 up time (since power on): 0:00:00

Time since the game was powered on.

8.1.7 clear coin audits

Select this to clear the coin audits.

8.1.8 cancel

Select this to leave the coin audits unchanged and return to the previous menu.

8.1.9 back

Select this to return to the previous menu.

8.2 Game audits

8.2.1 total 10 pin half-games: 0

Total number of 10-pin half games played. Two player games count 2, three player games count 3, and four player games count 4.

8.2.2 total full games: 0

Total number of full games played.

8.2.3 total series games: 0

Total number of three-game series games played.

8.2.4 total trick shot games: 0

Total number of track shot games played.

8.2.5 total blackjack games: 0

Total number of blackjack games played.

8.2.6 total ten pin poker games: 0

Total number of ten pin poker games played.

8.2.7 total average play time: 0:00:00 per dollar

Average amount of time played per dollar (or token) received. This gives the operator a sense of the rate at which the game is earning (average game time).

8.3 Detailed game audits

8.3.1 10 pin half-game audits

1) 1 player 10 pin half-games: 0

Number of one player 10 pin half-games.

2) 2 player 10 pin half-games: 0

Number of two player 10 pin half-games.

3) 3 player 10 pin half-games: 0

Number of three player 10 pin half-games.

4) 4 player 10 pin half-games: 0

Number of four player 10 pin half-games.

5) total 10 pin half-games: 0

Total number of 10 pin half-games.

6) 10 pin half-game total game time: 0:00:00

Total time playing 10 pin half-games

7) 10 pin half-game average game time: 0:00:00

Average time per 10 pin half-game.

8) 10 pin half-game average play time: 0:00:00 per dollar

Average amount of time played per dollar (or token) received.

9) back

Select this to return to the previous menu

8.3.2 10 pin game audits

Same as 10 pin half-game audits, above, except for full games.

1) 10 pin series audits

Same as 10 pin half-game audits, above, except for three-game series games.

2) trick shot audits

Same as 10 pin half-game audits, above, except for trick shot games.

3) blackjack audits

Same as 10 pin half-game audits, above, except for blackjack games.

4) ten pin poker audits

Same as 10 pin half-game audits, above, except for ten pin poker games.

5) back

Select this to return to the previous menu

8.4 Clear game audits

Select this to clear the game audits

8.4.1 cancel

Select this to leave the coin audits unchanged and return to the previous menu.

8.4.2 back

Select this to return to the previous menu.

9.0 DIAGNOSTICS

9.1 Audio tests

9.1.1 left test tone

Select this to output a 1kHz tone out of the left channel. The current volume setting is displayed during the test. Press start to end the test.

9.1.2 right test tone

Select this to output a 1kHz tone out of the right channel. Press start to end the test.

9.1.3 center test tone

Select this to output a 1kHz tone out of both channels. Press start to end the test.

9.1.4 back

Select this to return to the previous menu.

9.2 Switch tests

Each input in the machine is listed as follows:

push 1 (instant replay)

push 2 (score sheet)

push 3 (jukebox)

push 4 (start)

coin 1

coin 2

coin 3

service

volume up

volume down

horizontal 1 (yellow)

horizontal 2 (green)

vertical 1 (violet)

vertical 2 (blue)

track X (translated): 0

track Y (translated): 0

When an input is open its name appears in white. When closed, it appears in red. Close each switch in succession to verify correct operation.

To assist in the diagnosis of trackball problems each of the four trackball inputs are listed along with their wire colors. Also, a count is shown for X and Y as the ball is spun. If the trackball orientation adjustment is set to 45 degrees the word "translated" will appear.

Press the test button inside the coin door to exit switch tests.

9.3 Lamp tests

9.3.1 instant replay lamp

Select this to flash the instant replay lamp. Press start to cancel the test.

9.3.2 score sheet lamp

Select this to flash the score sheet lamp. Press start to cancel the test.

9.3.3 jukebox lamp

Select this to flash the instant replay lamp. Press start to cancel the test.

9.3.4 start lamp

Select this to flash the instant replay lamp. Press start to cancel the test.

9.3.5 back

Select this to return to the previous menu.

10.0 RESETS

10.1 clear credits

Select this to clear any credits currently pending to zero.

10.1.1 cancel

Select this to leave the credits unchanged and return to the previous menu.

10.2 set all adjustments to defaults

Select this to set all adjustments to their default values.

10.2.1 cancel

Select this to leave the adjustment unchanged and return to the previous menu.

10.3 clear coin audits

Select this to clear all of the coin audits to zero.

10.3.1 cancel

Select this to leave the coin audits unchanged and return to the previous menu.

10.4 clear game audits

Select this to clear all of the game audits.

10.4.1 cancel

Select this to leave the game audits unchanged and return to the previous menu.

10.5 set high scores to defaults

Select this to reset all of the high scores to their defaults.

10.5.1 cancel

Select this to leave the high scores unchanged and return to the previous menu.

10.6 set high scores to blank

Select this to reset all of the high scores to blank (no scores). This is useful when running in-house tournaments, as the high score screens are not cluttered with the fictional default high scores.

10.6.1 cancel

Select this to leave the high scores unchanged and return to the previous menu.

10.7 factory defaults (clear everything)

Select this to set all adjustments to defaults, clear all audits, and reset high scores to their defaults. Sets machine back to its initial factory state.

10.7.1 cancel

Select this to leave everything unchanged and return to the previous menu.

10.7.2 back

Select this to return to the previous menu.

10.8 system information

Shows the machine's serial number and software revisions. Press start to exit.

10.8.1 exit

Select this item to exit test mode and return to the game

11.0 TROUBLESHOOTING

For each of the symptoms below a list of items to check are provided. Go through the list in order to find the most likely cause of the problem.

11.1 No Power (everything is off)

- 1) Check that the power cord is plugged in and the game is turned on
- 2) Ensure that the service outlet which the game is plugged into is operational
- 3) Check that the power supply is plugged into the motherboard securely
- 4) Replace the power supply.

11.2 Game Powers On but Does Not Start Up

- 1) Listen for the pin crash sound on start up. This plays right as the game finishes its start up sequence and enters attract mode. If this plays but nothing appears on the screen, see "No Video On Screen", below.

11.3 No Video On Screen

- 1) When the game is first turned on the monitor should light up briefly and display the message "no signal". If this does not happen see "Monitor Does Not Seem to Work", below.
- 2) If the game does not start up (no pin crash sound is heard) check that all connections to the motherboard are correct and secure. Do this with the power off, then, turn the power back on.
- 3) If a computer monitor is available, try plugging it into the video card in place of the game's monitor. Some useful information may be obtained this way as the game attempts to start up.

11.4 Control Panel Error Message Appears On Screen

This message indicates that the game is unable to communicate with the i/o control board mounted under the control panel. This board reads the inputs and drives the lamps and the coin meter. Check to make sure that the i/o control board is plugged into the power supply and that the DB-9 serial cable connecting it to the motherboard is securely connected at both ends.

11.5 Coin Switches Do Not Work

Ensure that the coin door is plugged into the i/o control board under the control panel

11.6 Control Panel Switches Do Not Work

Ensure that the control panel harness is plugged into the i/o control board under the control panel.

11.7 Trackball Does Not Work or Works Erratically

- 1) Enter test mode and go to the switch test screen under "diagnostics".
- 2) Each of the four signals from the trackball are displayed along with their wire colors for easy identification. Roll the trackball. All four should toggle on and off.
- 3) If one or more do not toggle, check to make sure the trackball is properly plugged in and that none of the wires are broken or pulled out of one of the connectors.
- 4) If the wiring looks correct, the problem is probably with one of the opto encoders on the trackball. If none toggle the trackball is probably either unplugged or is not receiving power.

11.8 Buttons Do Not Light

- 1) Enter test mode and go to the lamp test under "diagnostics"
- 2) Check each lamp. Each test should make its lamp blink.
- 3) If none of the lamps work check that the control panel harness is undamaged and is properly plugged in to the i/o control board.
- 4) If one or more lamps do not work try replacing the bulbs. The switches are snapped into their bezels from underneath the control panel. The bezels do not need to be removed. Twist and pull the switch assembly out from underneath the control panel. Replace the bulb and perform the lamp test again. If the lamp is functioning snap the switch assembly back up into the bezel.
- 5) If replacing the lamp does not correct the problem the trouble may lie in the output driver on the i/o control board.

11.9 Monitor Does Not Seem to Work

- 1) When the game is first turned on the display should briefly light up and display "no signal". If this does not happen, check to make sure that the power cable from the monitor is plugged in securely to the power supply. This cable comes down from the tube which supports the monitor. If the display is getting power but never lights up, it will need to be removed for servicing.
- 2) If the display properly displays "no signal" at start up but then never displays any video from the game, even after the game finishes its start up sequence (as

indicated by the pin crash sound), check to make sure that the video cable from the monitor is securely connected to the video card on the motherboard. Also make sure that the video card itself is properly seated on the motherboard. Perform these checks with the power off, then reapply power to the game. If the game starts up but still no video appears, the problem is either with the video card or with the monitor.

12.0 MAINTENANCE

Spilled Liquids

The game is designed so that spilled liquids should not cause any damage. However, surfaces should be cleaned of any spills promptly to ensure a long service life for the game. Liquids spilled into the trackball are routed via a rail across the top of the lower housing over to the right side of the coin door then down and out through a drain hole in the bottom of the housing and down onto the base. All of these surfaces should be cleaned regularly to ensure they continue to keep liquids away from important components.

13.0 GAME PLAY

13.1 The Buttons

1. **START/SELECT (Checkmark Icon):** This button starts the game, resets the ball on the approach before taking a shot, selects shots in Trick Shot and selects cards in Ten Pin Poker.
2. **INSTANT REPLAY (Camera Icon):** This button plays a slow motion replay of the last shot. Press the button during the replay to change the camera angle.
3. **SCORESHEET (Score Box Icon):** Press and hold this button to bring up the score sheet during the game.
4. **JUKEBOX (Musical Notes Icon):** This button is used to change the song on the jukebox. Press it repeatedly to "break" the jukebox and shut it off. Press it again to start it back up.

13.2 How to Bowl, How to Bowl Better

13.2.1 Call Pins By Number

The pins are called out by number like this:

7	8	9	10
4	5	6	
	2	3	
	1		

Always call pins in order. The Lily, for instance, is called out as the 5-7-10, never the 7-5-10. The 1-pin is called the head pin, while the 5-pin is sometimes called the king pin.

The pin indicator at the upper right corner of the screen during the game shows which pins are standing. This can be helpful when one pin is hiding behind another (a "sleeper"). If you don't hit it just right the front pin will deflect one way while the ball deflects the other, leaving the sleeper standing.

13.2.2 Choosing a Ball

When you start the game you can choose to head straight to the lanes or stop in at the Pro Shop. If you go directly to the lanes you'll get a random 15 lb. ball. If you choose to go into the Pro Shop you can pick out your own ball. First choose out a ball. They all perform the same, so pick one based on how it looks. Next, you can pick the weight. A heavier ball will deflect less when hitting the pins, and will have more inertia, creating more pin action. A lighter ball will deflect more when glancing off a pin. It's easier to throw a light ball faster than a heavy ball.

13.2.3 Heading for the Pocket

The best chance for a strike comes from hitting the pocket. The pocket is the space between the head pin and the 3-pin for right-handed bowlers or the head pin and the 2-pin for left-handed bowlers. The greater the angle of entry into the pocket, the better the chances are for a strike. This is why experienced bowlers usually throw a hook ball.

13.2.4 Markings on the Lane

The dots and arrows on the lane are there to help you line up your shots. The dots right next to the foul line are roughly in line with the pins spotted on the pin deck. The large dot in the center is lined up with the head pin. You can follow the boards on the lane straight down from the large dot to the head pin. The boards are often numbered as you move away from the edges. Five boards from the left edge would be L5, while ten boards from the edge right would be R10.

The arrows part way down the lane allow for more advanced targeting. Rather than aiming for a pin, experienced bowlers will line up at a specific board on the approach and aim for an arrow. If the ball rolls over the arrow but doesn't end up where expected, the bowler will make an adjustment to the starting position on the approach or to the targeted arrow.

13.2.5 Throwing a Straight Ball

To throw a straight ball, line up your shot on the approach by rolling the ball left or right. To throw it just roll forward. The faster you roll the faster it goes, up to its maximum speed. A lighter ball will have a higher maximum velocity.

When throwing straight your chance of a strike is improved if you start off to one side and throw diagonally towards the pocket. It's a little trickier to aim when throwing diagonally across the lane but the results are worth the effort. Use the arrows for aiming.

13.2.6 Throwing a Hook Ball

Once you've mastered throwing the ball straight, the next step is to throw a hook. Throwing a hook requires adding spin to the ball. The lane is oiled so that it's slipperier towards the player and drier near the pin deck. If the ball is thrown with a diagonal spin, it will slide mostly straight on the slippery part of the lane then grab and turn in the direction of the spin when it reaches the drier part. This is how an experienced bowler causes the ball to hook.

To create the necessary spin to hook the ball, start by lining up on the approach by rolling the ball left or right. When you are in the right spot, start the ball spinning by pulling it straight backwards. You'll see the ball spin and a ring of spinning stars (the Spindicator) will appear to help indicate the direction and speed of the spin. At this point the ball can no longer move left or right on the approach. Rolling the ball left or right will change the angle of the spin, pulling it back will increase the speed of the spin. To throw it, roll forward in the direction you want the ball to go.

If you make a mistake while setting up your shot, press the START/SELECT button to cancel the spin. This will let you move the ball left or right on the approach again and start the shot over.

13.3 About the Games

1) Regulation Ten Pin Bowling

Regulation Ten Pin Bowling is just like what you play down at the lanes. You can choose to play a full game (ten frames), a half game (five frames), or a three-game series (three full games of ten frames each).

The Rules and Scoring

A game consists of ten frames. Each player gets two chances to knock down all ten pins on each frame. If all ten pins are knocked down on the first shot, the frame is marked as a strike and the second shot is not needed. If all pins are knocked down on the second shot the frame is marked as a spare. If less than ten pins are knocked down after two shots the frame is considered "open".

A strike scores ten points plus the pins knocked down on the next two shots. A spare scores ten points plus the pins knocked down on the next shot. An open frame scores the number of pins knocked down in that frame.

The tenth frame is treated special in that if the player gets a strike or a spare additional shots are required to finished the frame (two in the event of a strike, one in the event of a spare). This is because a strike scores ten plus the next two shots and a spare scores ten plus the next shot.

2) Trick Shot

In Trick Shot players choose from a variety of difficult leaves and try to pick them up. While some shots may look impossible every one can be picked up with enough practice.

The Rules and Scoring

Trick Shot has three kinds of shots: shots with only white pins, shots with white pins and red pins, and shots with white pins and targets on the lane. The player must knock down any white pins, avoid any red pins, and hit any targets to score. The shots are ranked by difficulty. The game adjusts the rankings of the shots over time based on the rate at which each shot is converted. Easier shots are worth fewer points while more difficult shots are worth more points.

3) Ten Pin Poker

Ten Pin Poker is played just like Regulation Ten Pin Bowling. Additionally, for each strike or spare the player gets a card (an operator adjustment can restrict cards to strikes only to increase the level of challenge). Each player can have up to five cards. At the end of the game the player with the best poker hand wins.

The Rules and Scoring

Scoring is just like Regulation Ten Pin. Additionally, players are awarded a card for each mark. If a player already has five cards, he or she must discard before drawing a new card. The player may opt to stand. As the game progresses a marker on the score sheet will indicate the player or players with the high hand. Hands are ranked using standard poker rules:

- 1) straight flush – a straight, all of the same suit. The Royal Flush is the highest possible hand (10-J-Q-K-A, all the same suit)
- 2) four of a kind – four cards of the same rank
- 3) full house – a pair and three of a kind
- 4) flush – five cards of same suit
- 5) straight – five cards whose rank are sequential. Ace may be high or low but not both (can't wrap, like Q-K-A-2-3)
- 6) three of a kind – three cards of the same rank
- 7) two pairs
- 8) pair – two cards of the same rank
- 9) high card

Suits are equivalent, so if two players have hands of the same rank which differ only by suit those hands are considered equivalent.

4) Blackjack Bowling

In Blackjack Bowling each player gets to throw at three full racks of ten pins each. The goal in each frame is to knock down 21 pins without going over. The player closest to 21 wins all the points for that frame.

The Rules and Scoring

Each player gets three full racks of ten pins per frame and tries to knock down a total of 21 pins without going over. Knocking down a single pin counts as an ace (one or eleven,

whichever is better). All pins knocked down are added to the pot for that frame. Whichever player gets closest to 21 without going over wins all the pins in the pot for that frame while the other players mark zero. A blackjack (a single pin and a strike -- an ace and a ten or face card) beats 21 earned on three throws. Blackjack doubles the number of points scored. In the event of a tie the pot is split evenly between the top scorers -- any remainder in the pot carries over to the next round.. Also, if all players bust the entire pot carries over into the next round.

14.0 OVERALL CONSTRUCTION

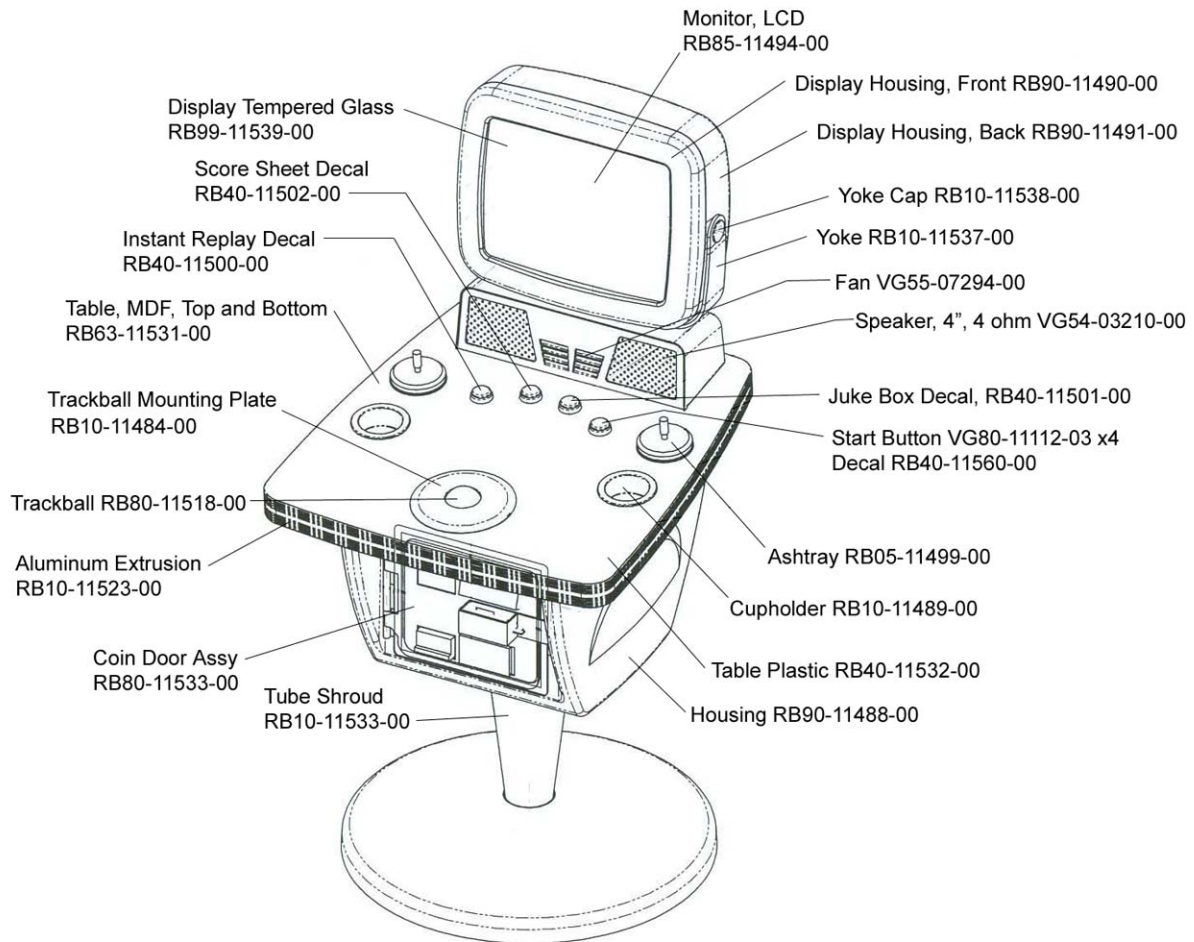

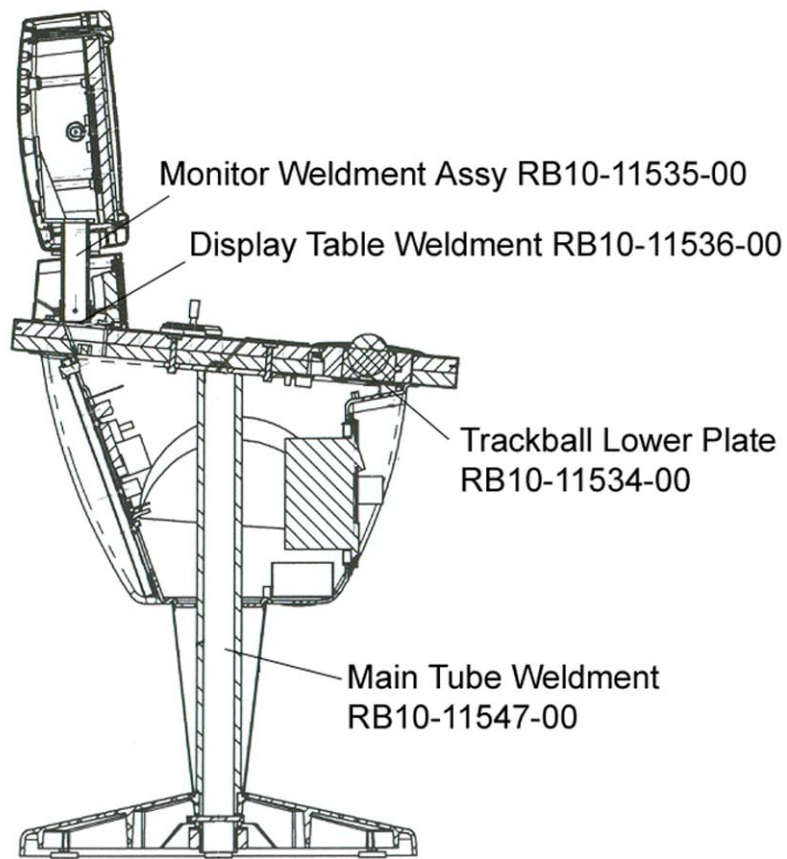

APPENDIX A: PARTS LIST

*See section 14 for overall game illustrations with part numbers.

IMPORTANT NOTE!

THE FOLLOWING PARTS ARE AVAILABLE AS A SET ONLY AND ARE NOT AVAILABLE SEPARATELY.

ONE SET CONSISTS OF ONE EACH OF THE FOLLOWING:

RB05-11520-00 PCB, CONTROL INTERFACE
RB05-11524-00 PCB, MOTHER BOARD, ASUS MB-P4S8XM
RB05-11528-00 HARD DRIVE, 40G, MAXTOR 6E040L0

DISPLAY ASSEMBLY

Part Number	Description
RB90-11491-00	DISPLAY HOUSING, BACK
RB90-11490-00	DISPLAY HOUSING, FRONT
RB10-11535-00	MONITOR WELDMENT ASSEMBLY
RB10-11536-00	DISPLAY WELDMENT ASSEMBLY
RB10-11537-00	YOKE
RB10-11538-00	DISPLAY YOKE CAP
RB99-11539-00	DISPLAY, TEMPERED GLASS
RB10-11540-00	DISPLAY FLAT PLATE
RB85-11494-00	MONITOR, LCD, LG 20.1" (640 X 480)
RB10-11541-00	DISPLAY L-BRACKET
RB10-11555-00	MOUNT (BRACKET), INVERTER PCB
RB05-11521-00	PCB, BACK LIGHT INVERTER
RB10-11556-00	MOUNT (BRACKET), DVI PCB
RB95-11557-00	CLAMP, DVI PCB
RB05-11498-00	PCB, DVI RECEIVER
RB50-11487-00	HARNESS, LCD INVERTER
RB50-11552-00	HARNESS, LCD POWER
RB50-11495-00	SINGLE LINK DVI-D CABLE (2 METERS)

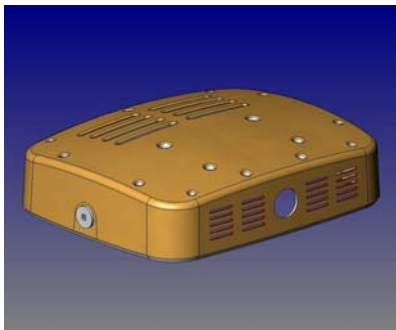

Display Housing, Back
 Outside View
 RB90-11491-00

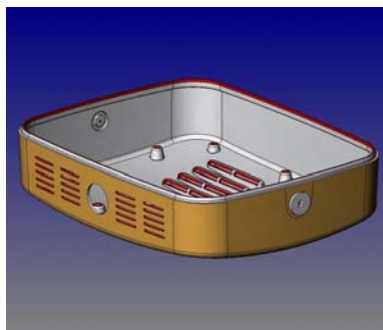

Display Housing, Back
 Inside View
 RB90-11491-00



Display Housing, Front
 RB10-11490-00



Monitor Weldment Assy
RB10-11535-00

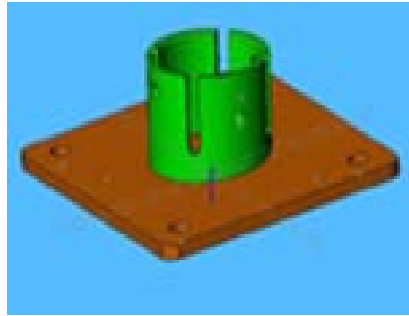

Display Weldment Assy
RB10-11536-00



Yoke
RB10-11537-00



Display Yoke Cap
RB10-11538-00

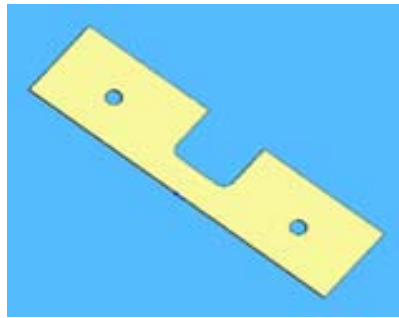

Display Flat Plate
RB10-11540-00



Display L-Bracket
RB10-11541-00

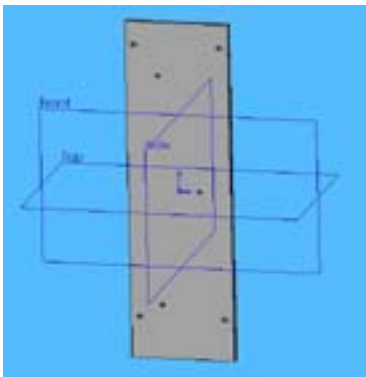

Bracket, Inverter PCB
RB10-11555-00

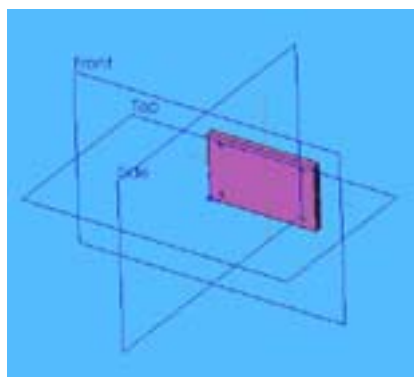

Bracket, DVI PCB
RB10-11556-00

CONSOLE ASSEMBLY

Part Number	Description
RB10-11545-00	CONSOLE FACE
RB10-11546-00	CONSOLE BACK
VG54-03210-00	SPEAKER, 4", 4 OHM, UNSHIELDED
VG55-07294-00	FAN, DC, 12V
RB05-11517-00	PCB, AMPLIFIER
RB05-11520-00	PCB, CONTROL INTERFACE

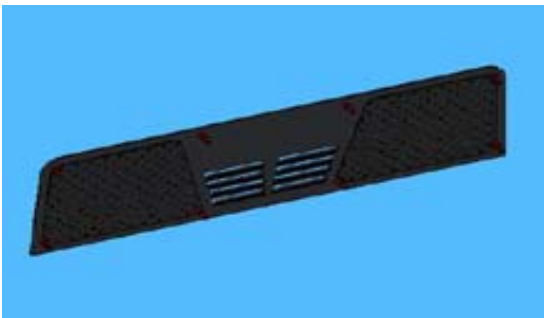

Console Face, RB10-11545-00

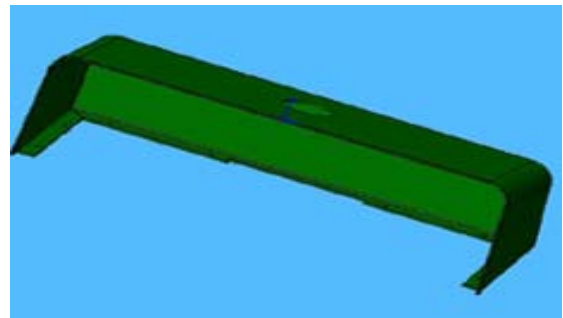

Console Back, RB10-11546-00

TABLE ASSEMBLY

Part Number	Description
RB63-11531-00	TABLE, MDF (top and bottom)
RB40-11532-00	TABLE, PLASTIC, 1/8" SILKSCREEN
VG80-11112-03	PUSHBUTTON W/ SWITCH, ILLU, MED, ROUND, CLEAR
RB40-11500-00	DECAL, LEGEND, INSTANT REPLAY
RB40-11501-00	DECAL, LEGEND, JUKEBOX
RB40-11502-00	DECAL, LEGEND, SCORE SHEET
RB40-11560-00	DECAL, LEGEND, START/SELECT
RB10-11489-00	CUP HOLDER
RB05-11499-00	ASH TRAY ASSEMBLY
RB10-11484-00	MOUNTING PLATE, TRACKBALL
RB80-11518-00	TRACKBALL ASSEMBLY W/HARNESS
RB10-11534-00	TRACKBALL LOWER PLATE
RB10-11523-00	ALUMINUM EDGE EXTRUSION, 2" X 10 FEET
RB50-11485-00	HARNESS, CONTROL PANEL
RB32-11516-00	LANYARD, 18", EYE TO EYE

HOUSING ASSEMBLY

Part Number	Description
RB90-11488-00	HOUSING, COMPLETE
RB10-11548-00	HOUSING, BACK DOOR
RB80-11483-00	COIN DOOR ASSEMBLY w/2coin mechs, 4 mini switches, meter and harness
RB10-11553-00	CASH BOX
RB10-11550-00	CPU MOUNT PLATE
RB05-11520-00 *	PCB, CONTROL INTERFACE
RB05-11524-00 *	PCB, MOTHER BOARD, ASUS MB-P4S8XMx
RB05-11525-00 *	PCB, VIDEO CARD, SAPHIRE/ATI 100573
RB05-11526-00	RAM, 256 MB, DDR400
RB05-11527-00	PCB. CPU, CELE-315BX
RB05-11528-00	HARD DRIVE, 40G, MAXTOR 6E040L0
RB88-11529-00	POWER SUPPLY, SPARKLE, 300W
RB50-11496-00	CABLE, SERIAL, DB9, MALE TO FEMALE, 1 TO 1, 3 FEET
RB50-11497-00	CABLE, AUDIO, 3.5MM STEREO, MALE TO MALE, 6 FEET
RB50-11551-00	HARNESS, DOLLAR BILL VALIDATOR
VG83-11252-00	DOLLAR BILL VALIDATOR

***AVAILABLE AS A SET ONLY**

One set consists of:

- RB05-11520-00 PCB, CONTROL INTERFACE
- RB05-11524-00 PCB, MOTHER BOARD, ASUS MB-P4S8XMx
- RB05-11528-00 HARD DRIVE, 40G, MAXTOR 6E040L0

SUPPORT LEG ASSEMBLY

Part Number	Description
RB10-11547-00	MAIN TUBE WELDMENT
RB10-11533-00	TUBE SHROUD

CONVENIENCE KIT

Part Number	Description
RB45-11559-00	MANUAL

APPENDIX B: WIRING DIAGRAM

WARRANTY

Seller warrants that its printed circuit boards and parts thereon are free from defects in materials and workmanship under normal use and service for a period of ninety (90) days from the date of shipment. Seller warrants that its video displays (in games supplied with video displays) are free from defects in material and workmanship under normal use and service for a period of thirty (30) days from the date of shipment. None of the Seller's other products or parts thereof are warranted. Seller's sole liability shall be, at its option, to repair, replace, or credit Buyer's account for such products which are returned to Seller during said warranty period, provided:

- a) Seller is promptly notified in writing upon discovery by Buyer that said products are defective.
- b) Such products are returned prepaid to Seller's plant; and
- c) Seller's examination of said products discloses to Seller's satisfaction that such alleged defects existed and were not caused by accident, misuse, neglect, alteration, improper repair, improper installation, or improper testing.

In no event shall Seller be liable for loss of profits, loss of use, incidental or consequential damages.

Except for any express warranty set forth in a written contract between Seller and Buyer which contract supersedes the terms herein, this warranty is in lieu of all other warranties expressed or implied, including the implied warranties of merchantability and fitness for a particular purpose, and all other obligations or liabilities on the Seller's part, and it neither assumes nor authorizes any other person to assume for the Seller any other liabilities in connection with the sale of products by Seller.

Namco America Inc. distributors are independent, being privately owned and operated. In their judgment they may sell parts or accessories other than **Namco America Inc.** parts or accessories. **Namco America Inc.** cannot be responsible for the quality, suitability or safety of any non-**Namco America Inc.** part or any modification including labor that is performed by such distributor.

SERVICE

If you have questions regarding any **Namco America Inc.** product or require technical support:

Contact **Namco America Inc.** Customer Service at:

(408) 200-7781 or FAX (408) 436-9554

Hours: 8:00 am - 4:00 pm PST

Parts and repair services for **Namco America Inc.** products are available through your distributor.

NAMCO AMERICA INC.

890 Service St. # C
San Jose, CA 95112
(408) 200-7781

FAX: (408) 436-9554

Technical Assistance (USA)

(408) 200-7781

Fax: (408) 436-9554

Reorder Number RB45-11559-00

REV. A FEBRUARY 2006

The specifications of this machine and the instructions in this Operation Manual are subject to change without notice for enhancement.